

Q Series Button



Q200

Q202

Q400



Q404

Q600

Q602

Q800



Q606



Q808



Q1000



Q1010



Q1200



Q1212



Safety · Reliability · Efficiency

User's Manual for Q Series Remote Control

1 Product Description

LCC industrial remote controller series is specially designed for the control of industrial machinery and equipment ; It's widely used in wireless remote control of a variety of industrial equipment, such as various cranes, tower cranes, conveyors and other crane equipment I .

the main features are as follows :

1. A total of 200 sets of remote control channels can be adjusted, completely replacing the traditional quartz single channel, solving the problem that easy broken and hard to get the channel.
2. Receiver have the function of automatic search transmitter channel: the use of replacement transmitter do not need professional equipment pairing, safe, it is simple and efficient.
3. More than 1 million sets of non-repeatable ID codes: superior to other industrial wireless remote controls on the market, the LCC family never repeats ID codes.
4. With advanced microprocessors : fast, high security, high accuracy and 100% correct coding and decoding.
5. More than 200 function settings : The transmitter and receiver have more than 200 function settings, can fully meet the various work needs of customers.
6. The whole series of products are completely compatible with software and hardware ,which avoid customers storing too many spare parts. customers can be prevented from unnecessary large inventory expenditures.
7. Rugged transmitter button: transmitter keystroke can reach 2 million times of continuous operation pressing, absolutely durable.
8. Power-saving design: the transmitter only needs two No. 5 "AA" alkaline batteries to operate and use for more than 100 hours.
9. Reinforced fiber plastic case: durable case for transmitter and receiver to prevent damage caused by strong impact and frequent drop.

2 Product Graphic Of Transmitter

A. Transmitter

1. Appearance graphic introduction

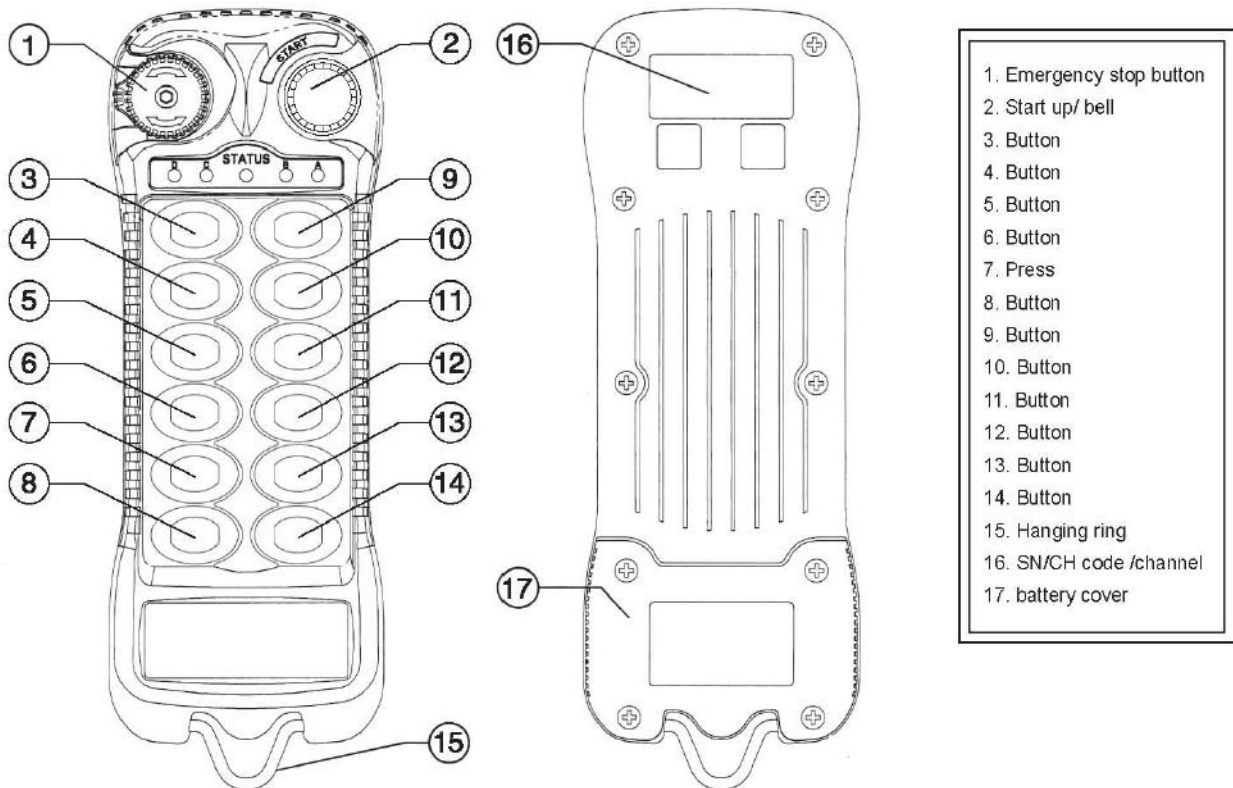

(Diagram 01)

(Diagram 02)

- | |
|--------------------------|
| 1. Emergency stop button |
| 2. Start up/ bell |
| 3. Button |
| 4. Button |
| 5. Button |
| 6. Button |
| 7. Press |
| 8. Button |
| 9. Button |
| 10. Button |
| 11. Button |
| 12. Button |
| 13. Button |
| 14. Button |
| 15. Hanging ring |
| 16. SN/CH code /channel |
| 17. battery cover |

3 Operation Instructions

Operating of transmitter

1. General operating procedures

1). Rotate the red emergency button located in the upper left corner of the transmitter clockwise or counterclockwise, and the button will pop up.

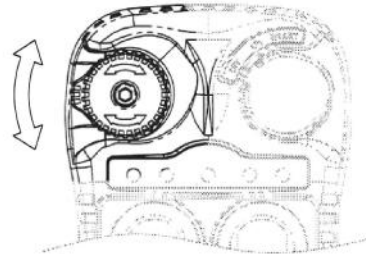

2). Press the green button and the green status means the start of the flashing remote control.

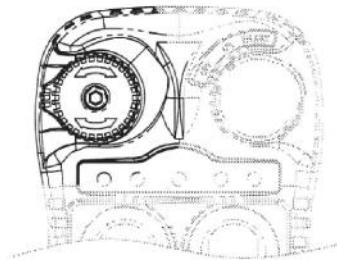
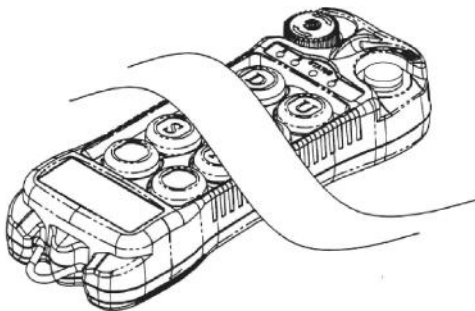

3). After startup, check the STATUS light on the transmitter to confirm that the system is normal ; under normal conditions, a green light will flash when the button is pressed.

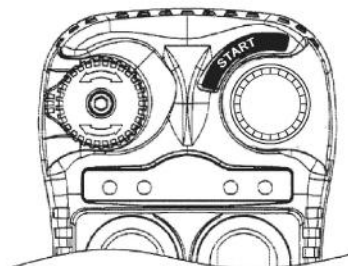

4). After completing the above operation procedures, press any button on the transmitter to control the crane or other equipment.

5). When the device is to be stopped, press the red emergency stop button of the transmitter immediately, and the receiver can cut off the total power of the device to stop the device. If you want to restart, redo the boot action, as in the above procedures 1. and 2 .

2. Replace the battery

Please open the battery cover on the back of the transmitter (Figure 13) . And use the No. 5 "AA" Alkaline batteries, After replacement, lock the battery cover to prevent dirt from seeping into the transmitter.

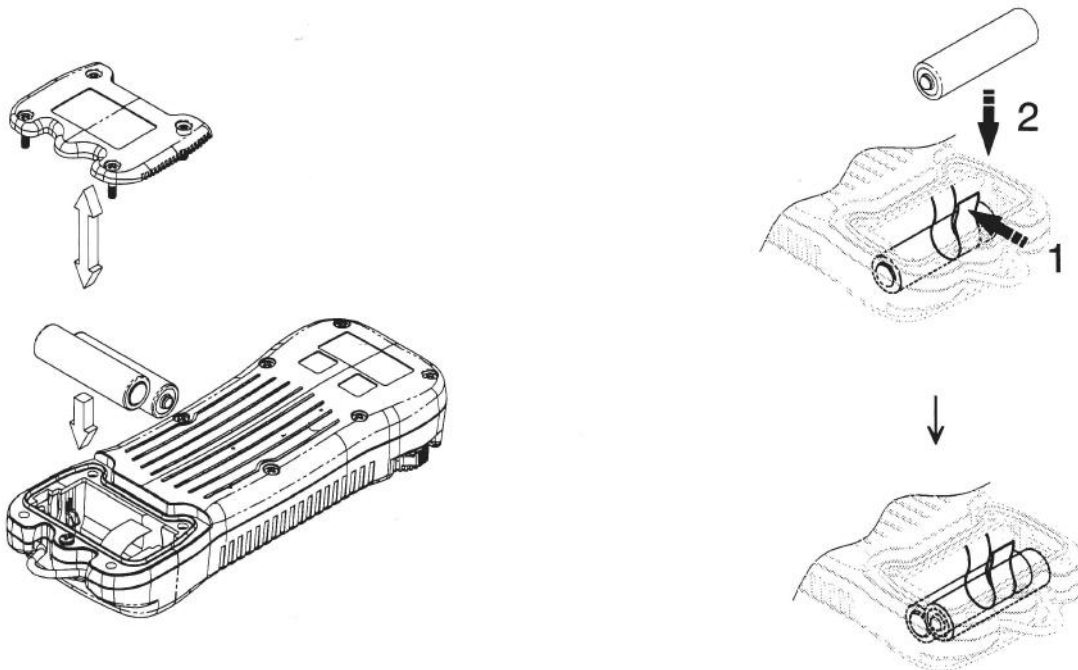

4

Simple Diagnosis / Troubleshooting For Transmitter

Please check whether the remote control handset is in good condition before using the remote control. When it is found that it cannot be operated normally, you can follow the steps below to perform simple lamp diagnosis and troubleshooting. If the following is still not normal, please inform the dealer for repair.

Red and green without indication Remarks : press any button without light indicator	Red light flashing / long bright	The green light is flashing
Diagnosis and failure analysis i No power. ii boot mode	Diagnosis and failure analysis i The battery spring piece is dirty. ii The battery power is insufficient. iii The battery itself is damage	Diagnosis and failure analysis i The receiver without sufficient power. ii The receiver without input power.
Solution i Please check the battery itself, damage or not. Or the battery joint dirt causes poor contact. ii Please replace the brand new battery and start the transmitter again. iii rechargeable battery needs to be charged or replaced with new one.	Solution i Please check if the battery itself is damaged or not. ii Check if the battery spring is dirty or not. iii Please replace the brand new battery and start the transmitter again.	Solution i Please check the power of receiver. ii Please check the fuse of receiver.

5 Technical index

Specification Table Of Transmitter

Frequency	MHz	433/480
Transmitter RF Power	mW	<10
Remote Control Distance	M	100
Power Supply	DC	LR6(AA)1.5Vx2 DC3V
Modulation		GFSK
Frequency Control		PLL
Antenna Impedance	Ω	50
Command Response Time	ms	<100
Stop Command Response Time	ms	<100
Average Power Consumption	mA@DC	8mA@DC3V
Working Temperature (regardless of battery temperature)		-35°C~+75
Net weight (with battery)	g	380g
Case Material		PA6+30% GF
Protection Level		IP65

Receptor Specification Table

Frequency	MHz	433/480
Receiving Sensitivity	dBm	-112
Remote Control Distance	M	100
Power Supply	AC/DC	Low voltage 24V 48V , high voltage 110V-460V
Modulation		GFSK
Frequency Control		PLL
Antenna Impedance	Ω	50
Reaction Time	ms	50~100
Power Capacity	A@AC	5A@250V
Average Power Consumption (standby)	mA@AC	15mA@AC220V
Operating Temperature		-35~+75
Net Weight	g	1700g
Case Material		PA6+30% GF
Protection Level		IP65

6 Product Warranty

Quality assurance

LCC guarantees that this product will meet the technical specifications shown in the factory when it leaves the factory. As long as it is installed correctly, it can be used normally.

During the Warranty time

This product enjoys a one-year shelf life from the date of shipment, and if it is during the warranty period, the non-human damage LCC is responsible for maintenance. Any product that requires repair must be sent to the service designated by LCC for repair. The customer is responsible for the one-way shipping cost of the product to the service, and LC will bear the return fee and return the product during the warranty period .

Unincluded items

The above warranty does not include Wear-and-tear parts such as buttons, relays, fuses, and batteries. Improper use of machine errors , irresistible causes, natural factors, inadequate maintenance, operating environment and specifications are ignored. Unauthorized changes, incorrect use, or fault damage caused by the customer setting the interface.

Remarks

There are no other warranties, express or implied, regarding the above warranty. The repairs provided by the warranty are the sole compensation of the customer and LCC is not responsible for any direct, indirect, special, accidental or causal liability.

7 Notes

General considerations

- ※ Personnel who have not been professionally trained shall not disassemble the machine, otherwise it may be damaged and cause casualties.
- ※ This manual is for reference only. Please consult the agent for detailed technical questions.

- ※ This machine has been closely tested before leaving the factory, but shall not be used in dangerous and potentially damaging circumstances,
- ※ After use, the total power supply of the equipment should be turned off, the power supply of the receiver should be cut off, and the key switch of the transmitter should be removed.
- ※ The transmitter should be placed in a safe place, and personnel should not be randomly pressed to avoid accidents.
- ※ Equipment should have total power relays, limit switches, and other safety facilities.
- ※ It should be discontinued in the event of lightning strike or interference.
- ※ Ensure that the transmitter battery is fully charged and the receiver voltage is normal.
- ※ When installing or repairing, turn off the total power of the equipment and the power supply in the receiver to avoid electric shock.
- ※ If necessary, the manufacturer will change the machine appropriately. Therefore, the content will be adjusted at any time based on the new machine without notice.

Operator precautions

- ※ Users must have received 0 series of operation training to familiarize themselves with the operation mode.
- ※ The operator must be in good health, good spirits, and be able to identify and judge the safety of the operation, and have a qualification certificate.
- ※ series of rugged transmitter can be quite resistant to impact and weather resistance, but too much or deliberate collision, extrusion, it may still be damaged.
- ※ The operation user should pay attention to the indicator light on the transmitter. If the red light continues to flash, there may be an abnormality or a fault condition, or the battery may be exhausted. At this time, stop the operation immediately and replace the battery light. It can be operated after normal.
- ※ If you find that the equipment is seriously disturbed, you must stop the operation immediately.
- ※ If you do not use the remote control for a long time, you must remove the battery inside the transmitter.

Installation Precautions

- ※ When installing the receiver, turn off the total power supply of the equipment and ensure that the power supply is cut off so as not to be electrocuted.
- ※ Receiver mounting position should be selected to avoid contact with sparks, such as remote motor, cable, inverter high voltage wiring, etc. Other sources of interference.
- ※ The fixed lock must be determined when the receiver is installed to avoid loosening and falling off the receiver.
- ※ Ensure understand the distribution of the crane and the setting of the remote control function (including relay output) to avoid causing incorrect wiring.
- ※ The receiver should not be installed in the electronic control box. the correct way to install the receiver is to fix the receiver in the appropriate position at the top (or outside) of the electronic control box, and then put the receiver output cable into the electronic control box to make the appropriate wiring.
- ※ There are 4 billion sets of security codes in this series of remote control. The security code settings are different before shipment. Please check if there is a remote control of the same channel within 100m range during installation to avoid interference.

8

Wiring Diagram

Q1000 Wiring Diagram

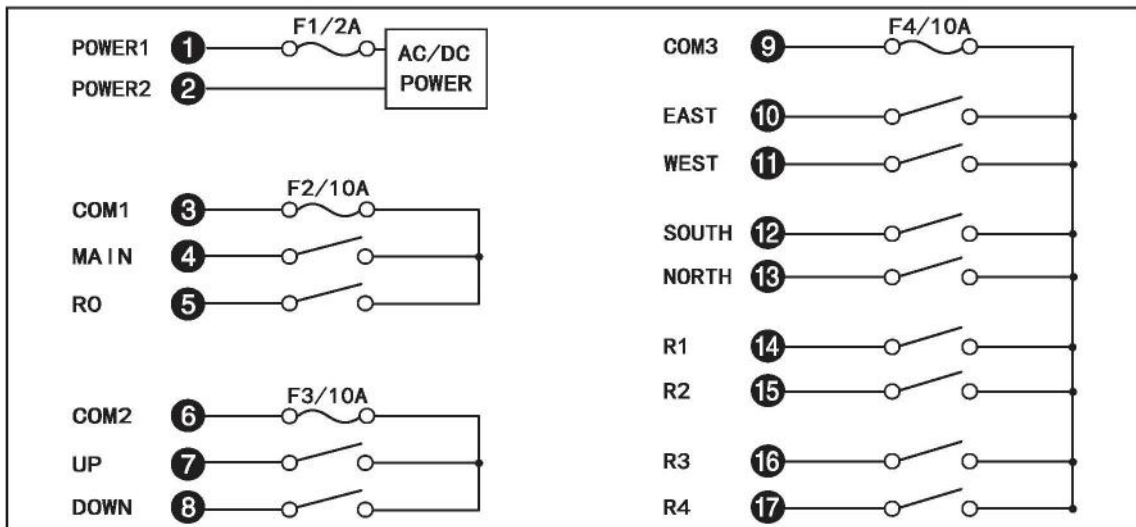

Q1200 Wiring Diagram

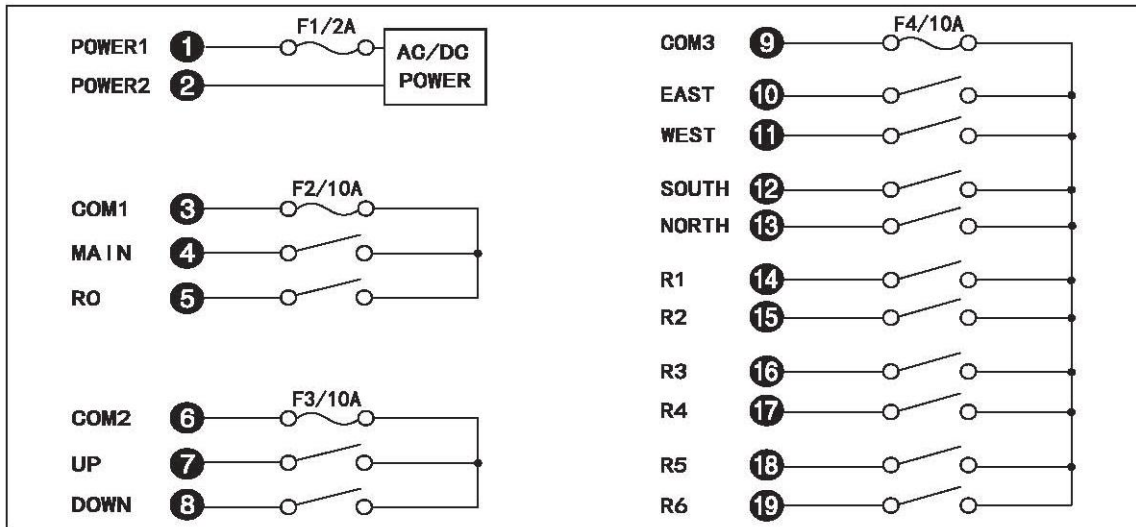

Q606 Wiring Diagram

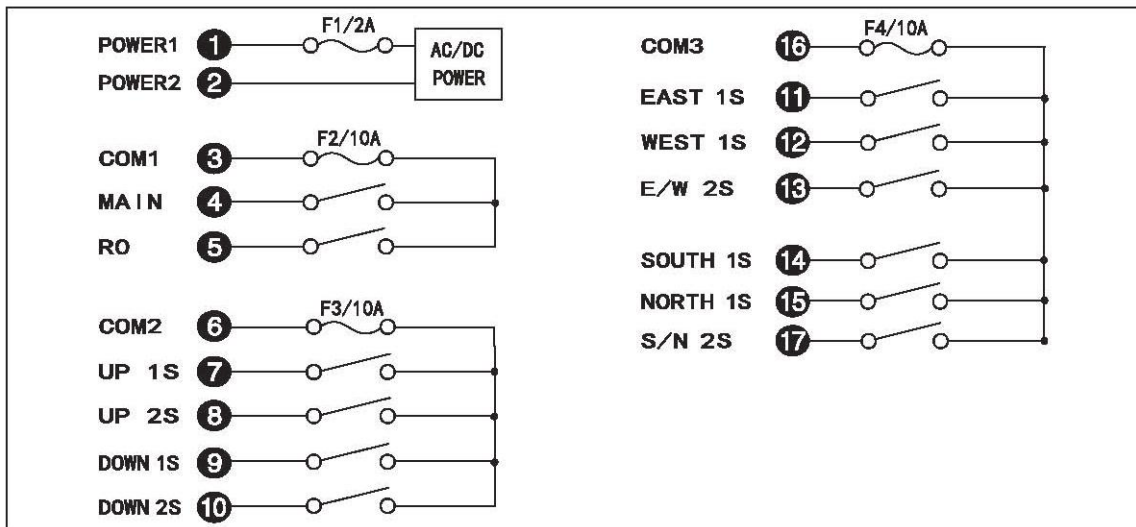

Q808 Wiring Diagram

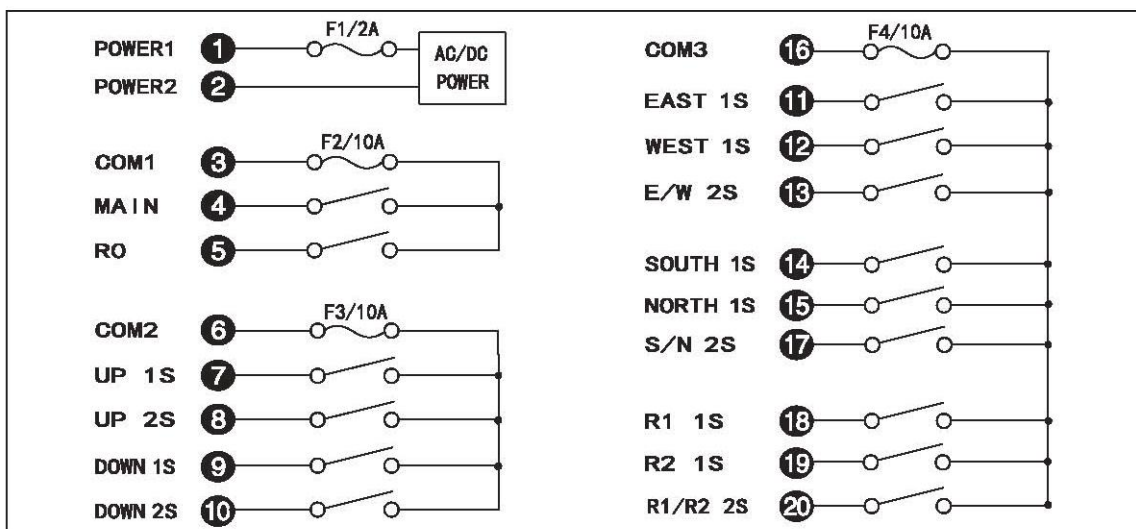

Q1010 Wiring Diagram

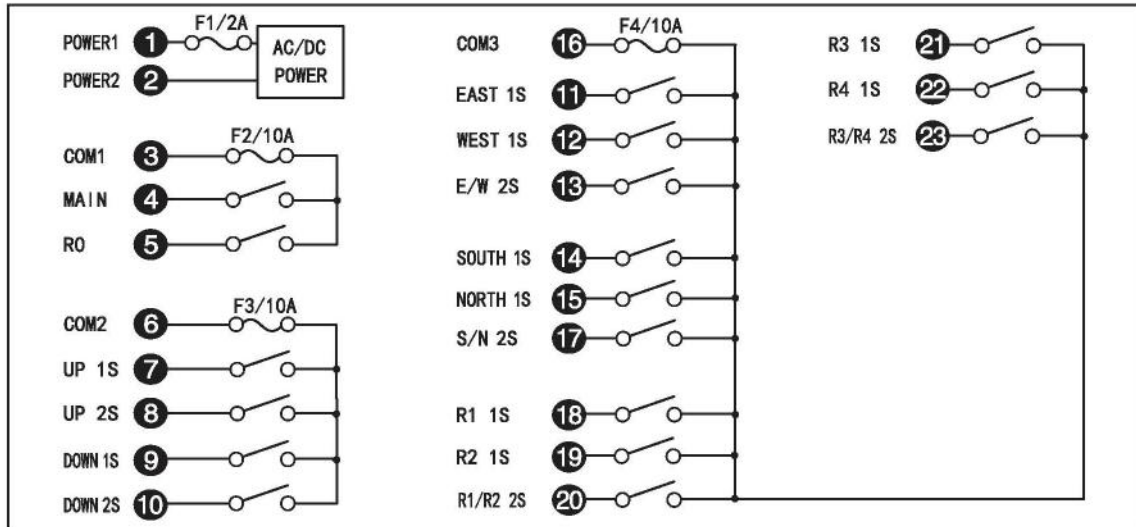

Q1212 Wiring Diagram

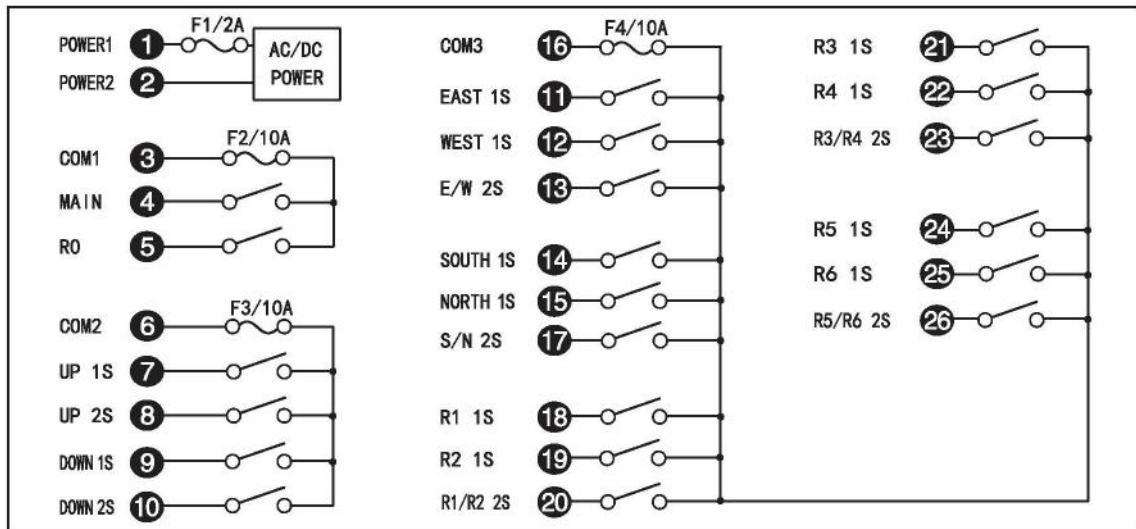

9 LCC-Q Series Wireless Pairing

The pairing of Transmitter and receiver :

1. the pairing mode of receiver : the receiver is powered on and the small black button "3 seconds" is held down on the receiving motherboard to wait for the traffic lights to flicker alternately.
2. The pairing mode of transmitter: when the transmitter with power, press the emergency stop , alternately press " up " and " down " four times, then he lights flash red and green alternately.
3. the transmitter presses the green start button (START) Don't let go, press " Down " , when all the lights are off, the receiver code and settings are successfully downloaded to the transmitter.

OUR COMPANY

Nanjing Xia Ding Electronic Technology Co., Ltd. is a high-tech enterprise specializing in R&D, production and sales of medium and high-end industrial wireless remote control systems. Its production base and sales headquarters are located in Jiangning Development Zone, Nanjing, Jiangsu Province.

The LCC brand was founded on the customer's desire for higher reliability of industrial wireless remote control. The vision of the brand was to provide safer, more reliable and more efficient industrial wireless remote control system to Chinese and global customers. Today, this vision has been turned into reality by LCC engineers, and now in every corner of the world, you have the opportunity to see LCC products. From ordinary industries such as steel metallurgy, automobile manufacturing, pulp and paper, shipbuilding, to mining, tunnel construction, port offshore, oil exploration and other special industries, LCC products are the primary choice for customers.



Our factory

Nanjing Xiading Electronic Technology Co., Ltd. has a more advanced manufacture equipment and a complete set of quality control system to ensure our products' quality

